

WITH 5-YEAR WARRANTY

Owner's Manual

Marlin[®]

CENTERFIRE

Lever Action Rifles

Models 336, 444 and 1895

IMPORTANT

This manual contains operating, care and maintenance instructions. To assure safe operation, any user of this firearm must read this manual carefully. Failure to follow the instructions and warnings in this manual can cause accidents resulting in injury or death. This manual should always accompany this firearm, and be transferred with it upon change of ownership.

The warranty card attached to the cover must be filled out and mailed within 10 days of purchase.

WARNING: KEEP THIS FIREARM OUT OF THE REACH OF CHILDREN, UNAUTHORIZED INDIVIDUALS, AND OTHERS UNFAMILIAR WITH THE SAFE HANDLING OF FIREARMS.

LIMITED WARRANTY AND CERTIFICATE OF OWNERSHIP

To insure warranty protection, this card must be completed and mailed within 10 days of purchase.

Model _____ **Serial Number** _____ **Date of Purchase** _____

I have read the Owner's Manual and request registration of my warranty. _____
(signature of owner)

Please Print

Owner _____ **Address** _____

City _____ **State** _____ **Zip Code** _____

e-mail _____

Name of Store where purchased _____ **City** _____ **State** _____

To help us provide new and better products we would appreciate your answers to the following questions.

Your Occupation

- Farm
- Student
- Office
- Industrial
- Professional
- Managerial

Your Age Group

- Under 18
- 18-24
- 25-34
- 35-49
- 50+

Which of these influenced your purchase?

- Previous experience with product
- Brand reputation
- Marlin web site
- Marlin advertisement
- Marlin catalog

Was this product a gift?

- Yes
- No



MFC
 P.O. Box 248
 North Haven, CT 06473-0903

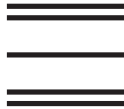

LIMITED WARRANTY
 The Marlin Firearms Company
**FIVE YEAR LIMITED WARRANTY AGAINST
 DEFECTS IN MATERIAL & WORKMANSHIP**

This firearm warranty is good only to the ORIGINAL OWNER who has registered his ownership with The Marlin Firearms Company at 100 Kenna Drive, North Haven, Connecticut. WARRANTY and CERTIFICATE OF OWNERSHIP card **must** be completed and mailed to The Marlin Firearms Company at the above address WITHIN TEN (10) DAYS of purchase to insure the protection of the warranty. NOTICE of defect in materials and/or workmanship **must** be received by the company WITHIN FIVE (5) YEARS from the date of purchase.

Normal wear, or damage resulting from neglect, abuse, alteration, or repairs not made or authorized by The Marlin Firearms Company or use of non-Marlin parts are not covered by the warranty.

THIS WARRANTY GIVES YOU SPECIFIC LEGAL RIGHTS, AND YOU MAY ALSO HAVE OTHER RIGHTS WHICH VARY FROM STATE TO STATE.

**MARLIN'S PERFORMANCE UNDER
 THE ABOVE WARRANTY**

1. After notice of defect in material and/or workmanship is received by The Marlin Firearms Company, Marlin shall send instructions for shipment of the firearm; and repairs will be made and the firearm returned within a reasonable time after the firearm is received. Cost of shipping, insurance charges, etc. involved in returning the firearm to the company shall be prepaid by the original owner.
2. Cost of parts and labor performed shall be provided without charge by The Marlin Firearms Company.
3. If The Marlin Firearms Company, after receipt of the firearm, determines that the defects in material and/or workmanship were the result of abuse and/or neglect, or otherwise not covered by the warranty set forth above, Marlin shall notify such owner to that effect and give an estimate for repair. In such cases, repair, return shipping and insurance charges, etc. shall be paid by such owner.
4. In the event that The Marlin Firearms Company is unable to make warranty repairs to the firearm, it shall, within a reasonable time after its receipt, notify the owner to that effect and give him the option either to receive a replacement of the same model, if then available in its inventory, or to receive a refund, either of which, if feasible, will be made through the store of purchase.

The Marlin Firearms Company
 100 Kenna Drive, North Haven, CT 06473-0905
www.marlinfirearms.com

NOTE: If your rifle is chambered for 444 Marlin, 45/70 Gov't. or 450 Marlin, please note the following warning and dimensions.

• **WARNING:** The cartridges shown below, actual size, indicate Industry Standard 444 Marlin, 45/70 Gov't and 450 Marlin dimensions. Use of ammunition, (see following note), that does not comply with these dimensions could cause personal injury and damage to the rifle.

NOTE: Hornady Evolution Ammunition, (with red, flexible bullet tip, 2.60" max. length), may also be used. Hard pointed bullets should not be used.

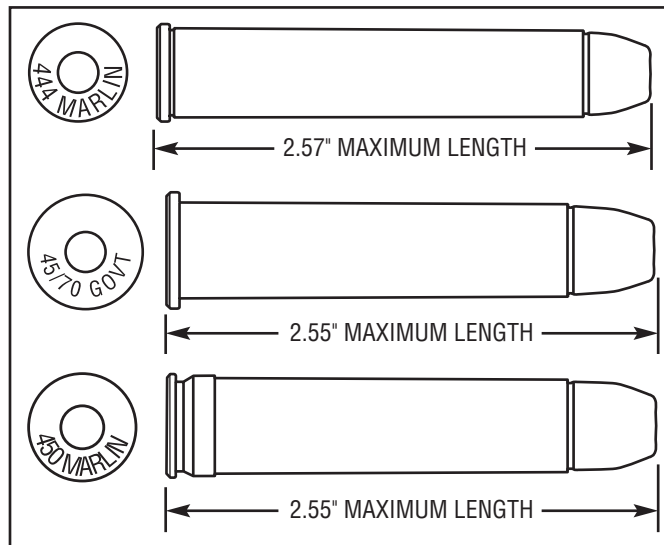

Before You Use This Firearm

It is very important that you read and understand this manual before using your firearm. Warnings should be read and heeded carefully. Also follow "Marlin's Guide to Gun Safety," printed in this manual.

• **WARNING:** Marlin firearms are designed and manufactured to handle standard factory-loaded ammunition which conforms to SAAMI (Sporting Arms and Ammunition Manufacturers' Institute Inc.) standards with dependability and safety. Due to the many bullet and load options available, the element of judgement involved, the skill required, and the fact that serious injuries have resulted from dangerous handloads, Marlin does not make any recommendations with regard to hand-loaded ammunition.

• **WARNING:** It is a violation of federal law to alter or deface the serial number of any firearm.

Use of the Offset Hammer Spur

• **WARNING:** Only use the offset hammer spur on the gun with which it was packed. It will not fasten securely on narrower ($\frac{1}{4}$ " Marlin or Glenfield hammers, or other hammers, and could cause a dangerous situation.

Because of its solid top, side ejecting receiver, your rifle is ideally suited for use with a scope. The receiver is drilled and tapped for scope mounting. However, once mounted, most scope and mount combinations do not allow sufficient clearance for your thumb between the eye-piece and hammer for safe operation. In order to operate the hammer safely, we recommend that you use the offset hammer spur packed with your rifle, when using a scope. A $\frac{1}{16}$ " hexagonal wrench for attaching the spur is also included.

For right hand use, position the offset hammer spur so that it protrudes from the right side of

the hammer, slide the offset hammer spur as far forward on the hammer as it will go, and tighten the set screw. For left hand use, mount the offset hammer spur so that it protrudes from the left side of the hammer, and tighten set screw. Be sure the set screw tightens into the small notch on either the right or left side of the hammer, and check regularly to be sure that it is tight.

•**WARNING:** Do not use the rifle with a scope unless the offset hammer spur is securely attached in the proper position. Make periodic checks to be sure the set screw securing the offset hammer spur to the hammer is tight.

Safety Features

Your rifle has a two-piece firing pin and trigger block, both of which prevent firing until the lever is completely closed. It is also equipped with two manual safety devices, a hammer block safety and a half cock safety notch, which, when used properly, provide an added degree of safety.

•**WARNING:** Before loading your rifle, become familiar with the operation of the hammer block safety and the hammer positions (FULL FORWARD, HALF COCK and FULL COCK), by practicing with the rifle unloaded.

•**WARNING:** Never disassemble the safety. It has been correctly designed, fitted and tested and is not reversible. Any mechanical device can fail, however, so never rely on the safety to justify careless handling. Never use a firearm with a safety that does not function properly.

1. How to Operate the Hammer Block Safety

The hammer block safety mechanism is a round button located at the rear of the receiver. To put your rifle on SAFE, first move the hammer to the Half Cock position (See D and #3 under "Safety Features").

NOTE: You can only move the safety button if the hammer is in the Half Cock or Full Cock position. It will not move if the hammer is in the Full Forward position, or if the hammer is resting on the safety in the SAFE position (slightly forward of Half Cock).

Push the safety button from left to right as far as it will go (See A). The safety is now on SAFE and the word SAFE will appear around the right side of the button. The hammer should now be in the Half Cock position and the safety on SAFE. *This is the safest way to carry your rifle when it is loaded.* At all other times the action should be open.

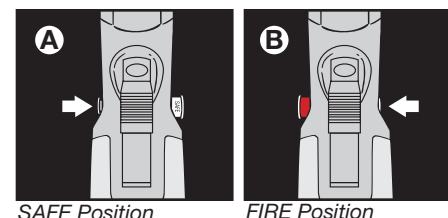

To move the safety button to the FIRE position, push it from right to left as far as it will go (See B). A red ring will appear around the left side of the button as a warning that it is in the FIRE position. *If the hammer is pulled all the way back at this point, the rifle will be cocked and ready to fire.*

2. Full Cock and Half Cock Hammer Positions

Exposed hammer lever actions have, for over a century, relied on manipulation of the hammer for both manual cocking of the rifle as well as the traditional Half Cock safety position. Your rifle has these traditional hammer positions as well as the added benefit of a hammer block safety button. Use the following hammer positions in conjunction with the hammer block safety for the safest possible operation.

A. The Full Cock position of the hammer is when it is at its furthest point from the firing pin (See C). If the trigger is pulled when the hammer is in this position, and the safety button is in the FIRE position, the gun will fire.

NOTE: If the trigger is pulled when the hammer is in the Full Cock position, and the rifle is on SAFE, the hammer *will fall*, but will be stopped before it strikes the firing pin.

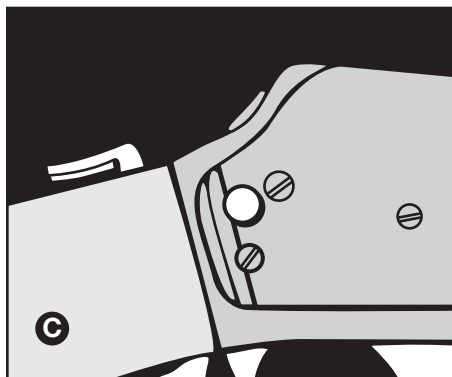

Full Cock

B. The Half Cock position of the hammer is between the Full Cock position and the full forward position. (See D).

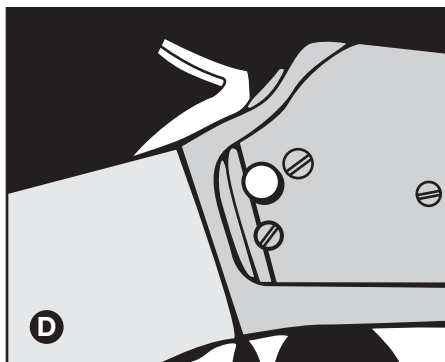

Half Cock

3. To Move the Hammer to the Half Cock Position

First put the hammer block safety button on SAFE. The hammer may be moved from Full Cock to the Half Cock position by firmly holding the hammer in the Full Cock position with your thumb. Keep your thumb on the hammer as you pull the trigger. As soon as you feel the hammer exerting forward pressure on your thumb, remove your finger from the trigger and ease the hammer slowly forward to the Half Cock position (See E & F). The hammer is now in the Half Cock "SAFE" position.

To resume the Full Cock position, simply pull the hammer all the way to the rear (See C).

Changing hammer position—

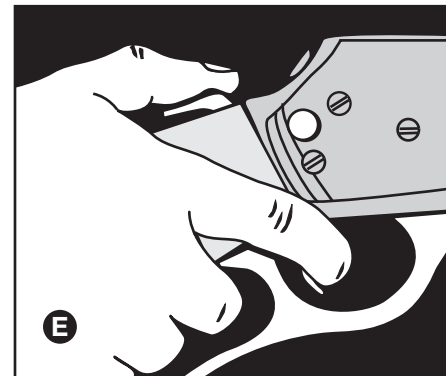

Full Cock to

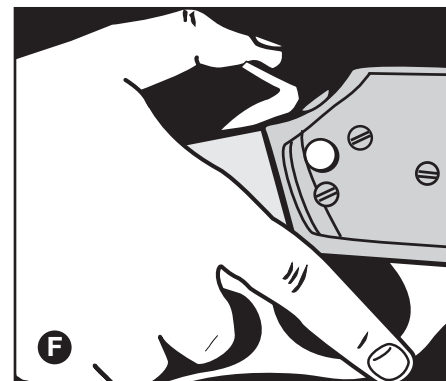

Half Cock

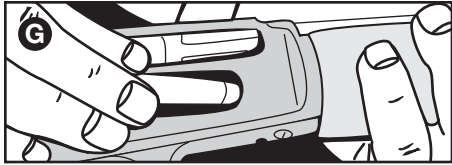

Loading the magazine

- **WARNING:** Any mechanical device can fail, so never rely on the Half Cock position or the hammer block safety to justify careless handling.
- **WARNING:** Never allow the hammer to rest on the firing pin (hammer in full forward position). If the rifle is loaded and the hammer is inadvertently struck in the full forward position, the rifle will fire.
- **WARNING:** Should the hammer inadvertently be placed in the Full Forward position, open the bolt, put the hammer block safety on SAFE, and close the bolt. The hammer is now in the Full Cock position. Follow instructions in #3 under "Safety Features" to move the hammer to the Half Cock position.

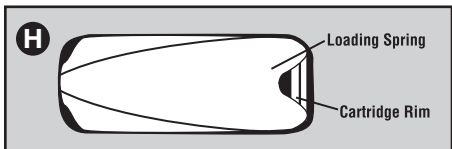

Proper position of loading spring

- **WARNING:** Become thoroughly familiar with the hammer positions before loading the rifle with ammunition. Failure to follow the instructions in #3 under "Safety Features" may result in "false half cock", a condition that may allow the hammer to fall and fire the rifle if the hammer block safety button is in the FIRE position, and the trigger is pulled.

How to Load

- **WARNING:** Before loading or firing, always check the bore and chamber to be sure they are free of grease, oil, or any other obstruction. With the action open, and the hammer block safety on SAFE, look through the barrel to see if there is an obstruction. If there is, it must be removed before firing. Otherwise, personal injury or damage could result.

Loading the Magazine

Be sure the bolt is closed (lever closed), the hammer block safety button is on SAFE (See A), the hammer is in the Half Cock position (See D), and the rifle is pointed in a safe direction. Insert the cartridges, bullet end first, into the loading port. As the cartridge enters the loading port, push it forward into the magazine tube (See G) **Be sure that the last cartridge is com-**

pletely inside the loading port before preparing to fire, or a jammed action may result (See H).

Preparing to Fire

With the rifle pointed in a safe direction, completely open and close the lever one time. When the hammer block safety button is moved to the FIRE position, your rifle is loaded, cocked, and ready to fire.

- **WARNING:** If you do not want to fire at this point, return the hammer block safety button to the SAFE position, and the hammer to the Half Cock position (See E & F).

Loading a Single Cartridge

With the hammer block safety button on SAFE, the rifle empty, and the lever open (bolt open), place a single cartridge with the bullet forward, in the ejection port, onto the carrier (See I).

Return the lever to the closed position (bolt closed). The cartridge will be fed directly

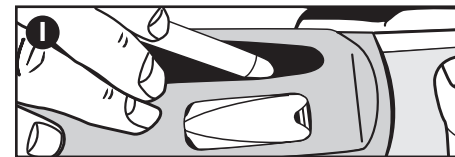

Loading a single cartridge

into the chamber and the rifle will be cocked and ready to fire, when the hammer block safety button is moved to the FIRE position.

- **WARNING:** Never attempt to load your rifle with ammunition that does not meet the cartridge designation stamped on the barrel. Use only ammunition suitable for a tubular magazine rifle. We recommend clean, dry, factory-loaded ammunition which conforms to industry standards.
- **WARNING Regarding Ammunition:** Some pointed and full metal jacket round nose bullets which are on the market can chain-fire other cartridges in a tubular magazine during recoil causing severe injury and damage. Hornady Lever Revolution ammunition has a soft pointed plastic tip, and can be used safely in your rifle. If you are uncertain about the safety of using a particular cartridge in your Marlin, contact the ammunition or bullet manufacturer.

How to Fire

With the hammer in the Full Cock position, push the hammer block safety button to the FIRE position and, with the gun pointed at the target, squeeze the trigger. The gun will fire. Work the lever fully open and closed for each repeat shot. If you do not fire all the cartridges in the magazine, be sure to put the hammer in the Half Cock position

and the hammer block safety button on SAFE until you are ready to shoot again.

- **WARNING:** Remember, until a visual check has been made, you must assume that a live round remains in the chamber. Whenever the action is closed, assume a live round is in the chamber.

What to do if Rifle Fails to Fire

Misfire

If you have squeezed the trigger and the hammer falls but the cartridge does not fire, remain in shooting position, pointing the gun in a safe direction. Count to 10, then open the action.

Underpowered Shot

A “squib”, or underpowered shot can normally be detected by the unusually low report it makes.

- **WARNING:** Because the bullet may actually still be in the barrel, you must unload completely and, with the action open, use a cleaning rod to see if there is an obstruction. If there is, it should be removed by a qualified gunsmith. Otherwise, personal injury or damage could result.

How to Unload

Put the hammer in the Half Cock position and the hammer block safety button on SAFE.

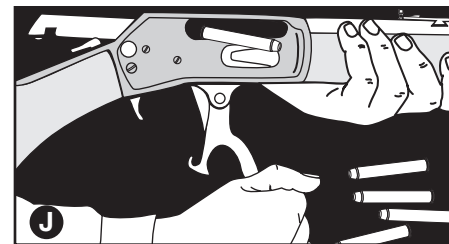

Unloading

Keeping your fingers away from the trigger, and with the gun pointed in a safe direction, manually eject all cartridges by opening and closing the lever, until you are sure the chamber and magazine are empty (See J). The lever must be completely closed and then fully opened to insure proper feeding and ejecting of all cartridges. Then, with the lever in the open position (bolt to the rear), inspect the chamber, carrier and magazine carefully to be sure there are no cartridges left in the gun.

- **WARNING:** During the unloading process, be sure the hammer block safety button is on SAFE, because each time the lever is completely closed (bolt closed), your rifle is cocked and ready to fire. Keep your fingers away from the trigger and be sure the gun is pointed in a safe direction during unloading.

Sighting

Your rifle has been sighted-in and test-fired at the factory. However, due to individual sighting characteristics, sighting should be range verified.

Rear Sight Adjustment Rule

To make corrections, always remember to move the rear sight in the direction in which you wish to move the center of the group. That is, if you are shooting low, raise the rear sight. If you are shooting to the right, move the rear sight to the left.

For Models Equipped With Elevator Adjustable Open Rear Sights

Horizontal Correction (Windage)

Windage adjustments to the rear sight can be made by gently tapping the dovetail portion of the rear sight in the desired direction.

To move the point of impact to the left, move the rear sight base to the left. To move the point of impact to the right, move the rear sight base to the right.

Vertical Correction (Elevation)

To raise the point of impact, raise the rear sight. To lower the point of impact, lower the rear sight. The sight can be

raised and lowered by moving the stepped elevator forward and back with your thumb.

For Models Equipped With Screw-Adjustable Rear Sights

Horizontal Correction (Windage)

To move the point of impact to the left or right, loosen the leaf binding screw until you can move the leaf manually. Move the leaf in the appropriate direction, retighten the screw and fire again. Continue this process until your shots are horizontally zeroed-in.

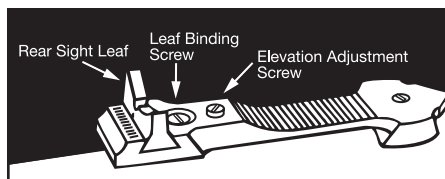

Screw-adjustable rear sight

Vertical Correction (Elevation)

To raise the rear sight (if you are shooting low) turn the elevation adjustment screw clockwise. To lower the rear sight (if you are shooting high) turn the elevation adjustment screw counterclockwise. Continue adjusting and firing until your shots are vertically zeroed-in.

Scope Mounting

Your rifle is drilled and tapped for scope mounts. They are made by Tasco, Weaver and others, and are available through your local gun dealer. You may also order directly from Marlin Gun Service. Call 1-800-544-8892 for more information.

• **WARNING:** Improper mounting or use of a scope may result in facial injury. Always allow sufficient space between the scope and eye to avoid contact from recoil. Be sure to follow the scope manufacturer's instructions for correct mounting and use. Periodically check the scope to ensure it has not moved during use.

How to Clean Your Rifle

• **WARNING:** Never attempt to wipe down or clean a loaded firearm.

Caution: Before using any solvent or other gun cleaning product, read the label carefully to be sure it will not damage either the finish, or any parts of this firearm.

NOTE for stainless steel models: Although stainless steel is corrosion-resistant, it can rust. If the rifle gets wet, dirty, or is subject to excessive handling, wipe down metal parts with oil or rust-inhibitor.

Minor scratches can be "buffed out" of stainless steel with a "Scotch-Brite™

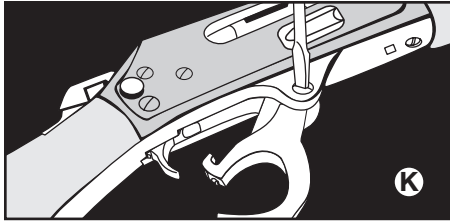

Removing lever screw

Very Fine” pad, available in hardware and automotive supply stores.

1. Put the hammer block safety button on SAFE and remove all cartridges from the action, chamber and magazine before you begin cleaning or inspecting your rifle.
2. To clean the bore from the breech end (recommended), open the lever half way, remove the lever screw (See K) and then the lever. Then remove the breech bolt from the receiver (See L). (This will cause the ejector to be loose inside the receiver

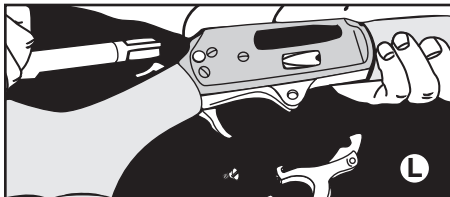

Removing breech bolt



Removing ejector

— be careful not to lose it.) Next, remove the ejector from the slot in the left side of the receiver (See M).

•WARNING: If you move the hammer block safety to the FIRE position after the bolt has been removed, do not pull the trigger, letting the hammer snap forward, because the hammer blow will damage the safety mechanism.

The bore can now be cleaned, using the proper caliber cleaning rod, cleaning patches and powder solvent. Clean and oil the breech bolt before replacing. The barrel and bore should also be *lightly* oiled.

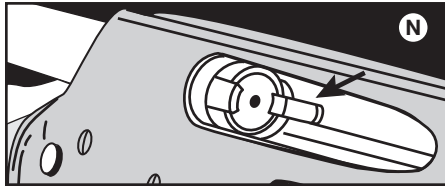

Correct bolt and ejector alignment

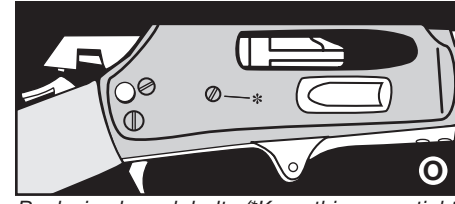

Replacing breech bolt (*Keep this screw tight)

3. The action may be cleaned and oiled while the gun is disassembled as described above.

4. To reassemble, simply reverse the above steps. Make sure the ejector is positioned properly prior to alignment and insertion of the breech bolt. See N for the relationship of the bolt and ejector for correct alignment. Push the breech bolt into the receiver until within approximately 1" of the fully closed position (See O). The lever may now be inserted as shown in P. Use a very thin coat of light oil during below freezing conditions. Condensation droplets



Replacing lever

will form soon after the rifle is brought into a warm room, or the rifle may become wet during inclement weather. In any case, all moisture should be removed. Exterior metal finishes may be wiped down with a slightly oiled cloth. For long term storage, lightly oil the bore, barrel and action with gun oil. Your rifle should be completely unloaded and stored in a dry, ventilated area. Do not store it in a carrying case.

Repair Instructions

Your firearm has been designed, engineered and manufactured in accordance with Marlin's rigid quality control standards. However, any mechanical device may occasionally require adjustment or repair.

Questions regarding the performance and serviceability of your firearm should be addressed to our Gun Service Division. You should include the Serial Number, Model Number and a full description of the conditions and problems involved.

Warranty Repairs

Our Warranty policy covers all our firearms against defects in workmanship or material for a period of five years from the date of purchase to the original owner. See the inside front cover of this manual for warranty details.

Guns requiring warranty repairs should be returned to the factory. Be sure to follow the "Shipping and Handling" instructions on this page.

Non-Warranty Repairs

A competent gunsmith may be able to repair your gun. If not, ship it to the factory, following the "Shipping and Handling" instructions on this page.

After receiving your firearm, we will send you an estimate of the repair cost. Repairs will begin upon receipt of your check or money order. If repairs are not possible, your gun will be returned.

Shipping and Handling

When sending your firearm to the factory, you must follow these instructions:

1. Prior to mailing, be absolutely certain that the chamber and magazine of your firearm are not loaded.
2. Pack your gun carefully. Use ample cushioning material and a sturdy outer cardboard box. Do not ship in a special container which you want returned.

3. Accessories such as scopes, scope mounts, gun case, quick detach type swivels, sling straps and other special appointments should be removed prior to returning the firearm.
4. Inside the box, include a sheet with the following information: model number, serial number, description of damage or problem, and under what conditions difficulty occurs.
5. **Keep a record of your serial number when returning a firearm.**
6. Clearly mark your return address on the outside of the box and on your instruction sheet.
7. Do not ship live ammunition under any circumstances.
8. Ship your firearm via insured Parcel Post or U.P.S. Shipment must be pre-paid and addressed to:

**MFC INC.
ATTN: SERVICE DEPT.
100 KENNA DRIVE
NORTH HAVEN, CONN. 06473**

IMPORTANT

If you have any questions or problems relating to your new Marlin, would like additional information on safe operation, or wish to order parts or accessories, just call our Customer Service Center. A Service Representative can be reached at the number listed below, between 8 A.M. and 4:30 P.M. (Eastern Time), Monday through Friday.

1-800-544-8892
(Toll Free)

Please record the firearm serial number, date of purchase and where purchased below.

Serial #: _____

Date of Purchase: _____

Purchased From: _____

In case of loss or theft, supply this information to the proper authorities.

The Fascinating History of Marlin

Written by the late William S. Brophy, Marlin's Senior Technical Manager and Official Company Historian for many years, this prodigious book details the history of the Marlin Firearms Co. and its products. The hardbound volume contains more than 600 pages and over 1000 illustrations. Must reading for anyone interested in all the models — pistols, rifles and shotguns — made by Marlin, and in the story of more than a century of firearms production in America.

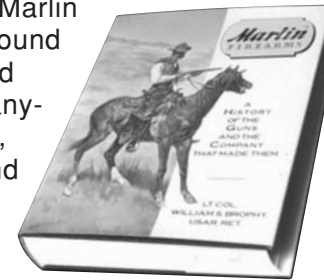

For more information, write:
Marlin Firearms Co.
Department OM
100 Kenna Drive
North Haven, CT 06473

Marlin's Guide to Gun Safety

1. Read and understand the owner's manual before using a firearm.
2. If you are unfamiliar with firearms, attend a firearms safety class taught by a certified instructor.
3. Handle every firearm as if it were loaded and ready to fire.
4. Control the muzzle, and never point a firearm at anything you don't want to shoot.
5. Keep the safety on SAFE until you are ready to shoot.
6. Unless you are hunting, carry your firearm empty, with the action open.
7. Before shooting, be sure you have an adequate backstop. All ammunition is dangerous beyond your line of sight.
8. Avoid ricochets by never shooting at water or any hard, flat surface.
9. Do not run, climb, or jump over an obstacle with a loaded firearm.
10. Do not climb into or out of a tree or tree stand with a loaded firearm.
Do not allow others to pass loaded firearms to you while in a tree stand.
11. Do not enter or ride in a motor vehicle with loaded firearms.
12. Do not lean a loaded firearm against anything.
13. Do not bump, drop or jar a loaded firearm.
14. Do not pull a firearm toward you by the muzzle.
15. Wear hearing protectors when shooting.
16. Wear impact-protective glasses when shooting, disassembling or cleaning firearms.
17. Avoid alcoholic beverages and drugs before and during shooting.
18. Use only ammunition of the correct gauge, caliber, size and bullet shape for your firearm.
19. Do not use damaged, dirty, modified, or improperly handloaded ammunition.
20. Keep the barrel and mechanism of the firearm free of obstructions.
21. Do not use a firearm that fails to function properly. Do not try to force a jammed action.
22. Be sure no one is in the path of ejecting shells or cartridges.
23. Do not interchange parts between firearms, and be sure disassembly and reassembly are correct and complete.
24. Before cleaning, be sure the chamber, action and magazine are completely unloaded.
25. Unload firearms before storing, transporting, or leaving unattended.
26. Store firearms and ammunition separately, locked and out of the reach of children.

Failure to follow these rules, or other instructions in this manual, can result in personal injury.

Printed in U.S.A.

WARNING

Children are attracted to and can operate firearms that can cause severe injuries or death.

Prevent child access by always keeping guns locked away and unloaded when not in use. If you keep a loaded firearm where a child obtains and improperly uses it, you may be fined or sent to prison.

ADVERTENCIA

A los niños los atraen las armas de fuego y las pueden hacer funcionar. Ellos pueden causarse lesiones graves y la muerte.

Evite que los niños tengan acceso a las armas de fuego guardándolas siempre con llave y descargadas cuando no las esté utilizando. Si usted tiene un arma de fuego cargada en un lugar en que un niño tiene acceso a ella y la usa indebidamente, le pueden dar una multa o enviarlo a la cárcel.

Health Warning: Discharging of firearms in poorly ventilated areas and handling ammunition may cause exposure to lead and/or lead compounds. Exposure may cause cancer, birth defects or damage to the kidney, nervous, blood forming and reproductive systems. Have adequate ventilation at all times, especially in confined areas. Wash hands thoroughly after shooting, handling ammunition, or cleaning a firearm. Do not eat or smoke during these activities.

Safety Warning: Marlin strongly recommends that you take a hunter safety course, taught by a certified instructor, before you use this firearm. Your State Fish & Game Dept. or a local gun shop can suggest courses in your area.

Safety Warning: Keep this firearm out of the reach of children, unauthorized individuals, and others unfamiliar with the safe handling of firearms.

10/05 485001

Marlin®

CENTERFIRE Lever Action Rifles Models 336, 444 and 1895

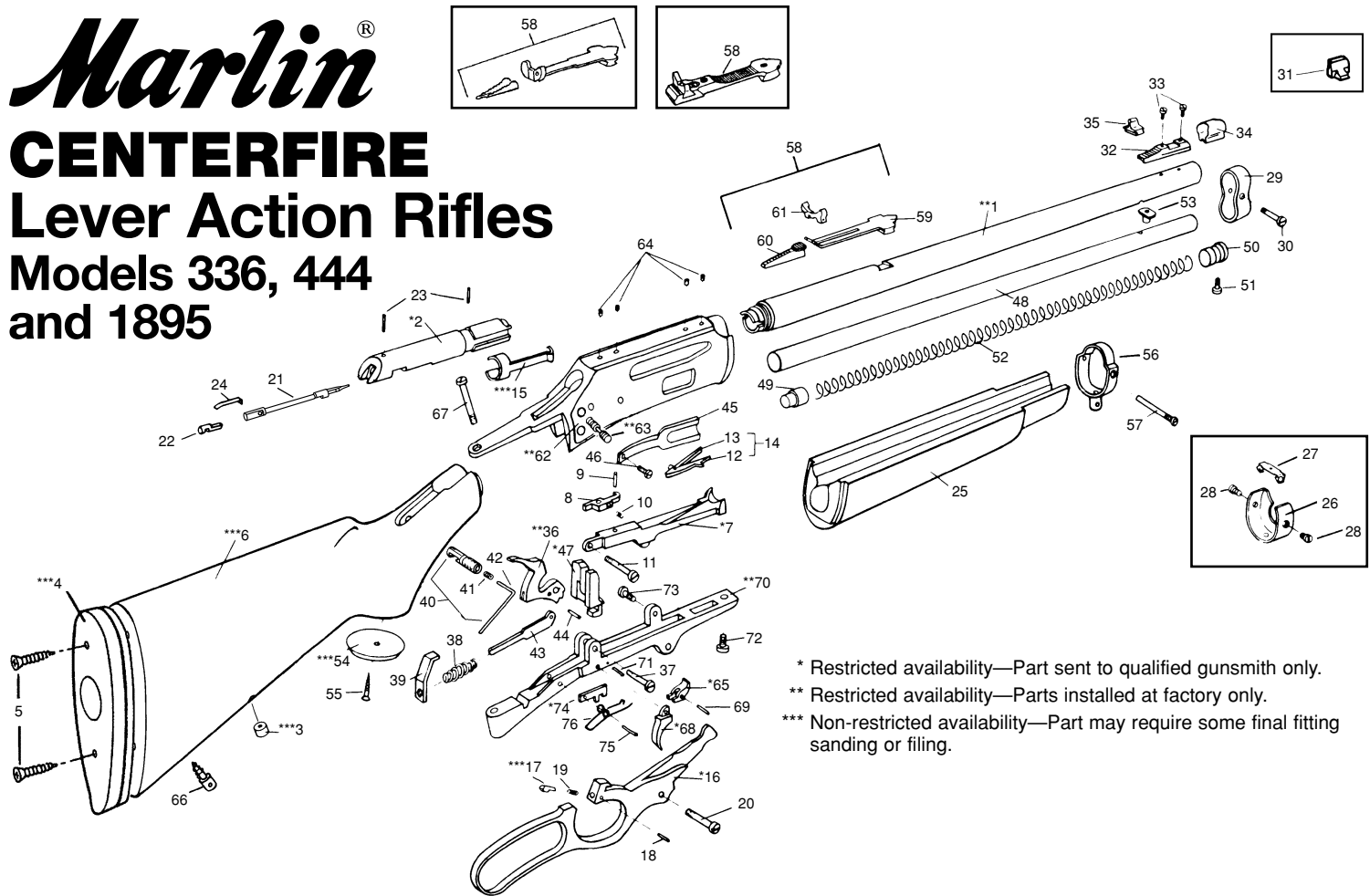

* Restricted availability—Part sent to qualified gunsmith only.
 ** Restricted availability—Parts installed at factory only.
 *** Non-restricted availability—Part may require some final fitting sanding or filing.

PARTS LIST CENTERFIRE LEVER ACTION RIFLES

For parts prices, call 1-800-544-8892 (8 A.M. to 4:30 P.M., Eastern Time, Weekdays)
 Be sure to mention gun serial number when ordering parts

ILL. NO.	PART NAME	ILL. NO.	PART NAME	ILL. NO.	PART NAME
**1	Barrel	25	Forearm	51	Magazine Tube Plug Screw
*2	Breech Bolt	26	Forearm Tip	52	Magazine Tube Spring
***3	Bullseye	27	Forearm Tip Tenon	53	Magazine Tube Stud
***4	Buttplate/Buttpad	28	Forearm Tip Tenon Screw (2)	***54	Pistol Grip Cap
5	Buttplate Screw (2)	29	Front Band	55	Pistol Grip Cap Screw
***6	Buttstock	30	Front Band Screw	56	Rear Band
*7	Carrier	31	Front Sight	57	Rear Band Screw
8	Carrier Rocker	32	Front Sight Base	58	Rear Sight Assembly
9	Carrier Rocker Pin	33	Front Sight Base Screw (2)	59	Rear Sight Base
10	Carrier Rocker Spring	34	Front Sight Hood	60	Rear Sight Elevator
*	Carrier Assembly (Not shown) (Consisting of above 4 parts)	35	Front Sight Insert	61	Rear Sight Folding Leaf
11	Carrier Screw	**36	Hammer	**62	Receiver
12	Ejector	37	Hammer Screw	**63	Safety Button Assembly
13	Ejector Spring	38	Hammer Spring (Mainspring)	64	Scope Mount Dummy Screw (4)
14	Ejector w/Spring	39	Hammer Spring Adjusting Plate	*65	Sear
***15	Extractor	40	Hammer Spur Complete (Includes parts 41 and 42)	66	Swivel Stud, Rear
*16	Finger Lever	41	Hammer Spur Screw	67	Tang Screw
***17	Finger Lever Plunger	42	Hammer Spur Wrench	*68	Trigger
18	Finger Lever Plunger Pin	43	Hammer Strut	69	Trigger and Sear Pin
19	Finger Lever Plunger Spring	44	Hammer Strut Pin	**70	Trigger Guard Plate
20	Finger Lever Screw	45	Loading Spring	71	Trigger Guard Plate Latch Pin
21	Firing Pin, Front	46	Loading Spring Screw	72	Trigger Guard Plate Screw
22	Firing Pin, Rear	*47	Locking Bolt	73	Trigger Guard Plate Support Screw
23	Firing Pin Retaining Pin (2)	48	Magazine Tube	*74	Trigger Safety Block
24	Firing Pin Spring	49	Magazine Tube Follower	75	Trigger Safety Block Pin
		50	Magazine Tube Plug	76	Trigger Safety Block Spring

ILL. NO.	PART NAME	336SS 30/30 Win. Part No.	336C 35 Rem. Part No.	336C 30/30 Win. Part No.	336CC 30/30 Win. Part No.	336W 30/30 Win. Part No.	336A 30/30 Win. Part No.	336Y 30/30 Win. Part No.	336CB 38/55 Win. Part No.	444 444 Marlin Part No.	1895M 450 Marlin Part No.	1895MR 450 Marlin Part No.	1895G 45/70 Govt. Part No.	1895GS 45/70 Govt. Part No.	1895 45/70 Govt. Part No.	1895CB 45/70 Govt. Part No.
**1	Barrel	101034	101001	101000	101055	101006	101008	101080	101010	101002	101079	101082	101078	101077	101003	101057
*2	Breech Bolt	101686	101886	101686	101686	101686	101686	101686	101686	101686	101049	101049	101986	101986	101986	101986
***3	Bullseye	320101	320101	320101	N/A	N/A	N/A	N/A	320101	320101	320101	320101	320101	320101	320101	320101
***4	Buttplate/Buttpad	417002	417002	417002	N/A	320402	320402	420008	320402	417002	410802	410802	410802	410802	417002	320402
5	Buttplate Screw (2)	420590	420590	420590	420590	420590	420590	420590	420590	420590	420590	420590	420590	420590	420590	420590
**6	Buttstock	501214	501214	501214	501046	501814	501814	501057	514314	501214	501319	501060	501319	501319	501214	514314
*7	Carrier	101042	101161	101161	101161	101161	101161	101161	101161	101461	101461	101461	101461	101065	101461	101461
8	Carrier Rocker	201063	201063	201063	201063	201063	201063	201063	201063	201063	201063	201063	201063	201063	201063	201063
9	Carrier Rocker Pin	401062	401062	401062	401062	401062	401062	401062	401062	401062	401062	401062	401062	401062	401062	401062
10	Carrier Rocker Spring	401094	401094	401094	401094	401094	401094	401094	401094	401094	401094	401094	401094	401094	401094	401094
*	Carrier Assembly (Not shown) (Consisting of above 4 parts)	501034	501161	501161	501161	501161	501161	501161	501161	501461	501461	501461	501461	501051	501461	501461
11	Carrier Screw	301001	301190	301190	301190	301190	301190	301190	301190	301190	301190	301190	301190	301001	301190	301190
12	Ejector	201004	201168	201168	201168	201168	201168	201168	201168	201168	201168	201168	201168	201004	201168	201168
13	Ejector Spring	401294	401294	401294	401294	401294	401294	401294	401294	401294	401294	401294	401294	401294	401294	401294
14	Ejector w/Spring	501028	501168	501168	501168	501168	501168	501168	501168	501168	501168	501168	501168	501028	501168	501168
***15	Extractor	201001	301169	301169	301169	301169	301169	301169	301169	301269	301269	301269	201369	201469	201369	201369
*16	Finger Lever	501035	501170	501170	501170	501170	501170	501170	501170	501170	501170	501170	501170	501068	501570	501170
***17	Finger Lever Plunger	201071	201071	201071	201071	201071	201071	201071	201071	201071	201071	201071	201071	201071	201071	201071
18	Finger Lever Plunger Pin	301009	301197	301197	301197	301197	301197	301197	301197	301197	301197	301197	301197	301009	301197	301197
19	Finger Lever Plunger Spring	401696	401696	401696	401696	401696	401696	401696	401696	401696	401696	401696	401696	401696	401696	401696
20	Finger Lever Screw	301002	301192	301192	301192	301192	301192	301192	301192	301192	301192	301192	301192	301002	301192	301192
21	Firing Pin, Front	401499	401499	401499	401499	401499	401499	401499	401499	401499	401499	401499	401499	401499	401499	401499
22	Firing Pin, Rear	401012	401199	401199	401199	401199	401199	401199	401199	401199	401199	401199	401199	401012	401199	401199
23	Firing Pin Retaining Pin (2)	420299	420299	420299	420299	420299	420299	420299	420299	420299	420299	420299	420299	420299	420299	420299
24	Firing Pin Spring	401295	401295	401295	401295	401295	401295	401295	401295	401295	401295	401295	401295	401295	401295	401295
25	Forearm	101817	101817	101817	101056	101223	101123	101027	114628	101917	101917	101917	101917	101917	101917	101337
26	Forearm Tip	N/A	N/A	N/A	N/A	N/A	501328	N/A	214128	501828	501828	501828	501828	501036	501828	101129
27	Forearm Tip Tenon	N/A	N/A	N/A	N/A	N/A	220429	N/A	220429	220629	220629	220629	220629	220629	220629	220429
28	Forearm Tip Tenon Screw (2)	N/A	N/A	N/A	N/A	N/A	320191	N/A	320191	320191	320191	320191	320191	101067	320191	320191
29	Front Band	301010	301233	301233	301233	301233	301233	301233	N/A	N/A	N/A	N/A	N/A	N/A	N/A	N/A
30	Front Band Screw	301011	301291	301291	301291	301291	301291	301291	N/A	N/A	N/A	N/A	N/A	N/A	N/A	N/A
31	Front Sight	N/A	N/A	N/A	N/A	N/A	N/A	N/A	414144	N/A	N/A	N/A	N/A	N/A	N/A	414144
32	Front Sight Base	221239	220539	220539	220539	220539	220539	220539	N/A	221139	221139	221139	221139	221139	221139	N/A
33	Front Sight Base Screw (2)	320991	320190	320190	320190	320190	320190	320190	N/A	320991	320991	320991	320991	320991	320991	N/A
34	Front Sight Hood	320245	320245	320245	320245	320245	320245	320245	N/A	320245	320245	320245	320245	320245	320245	N/A
35	Front Sight Insert	230744	330644	330644	330644	330644	330644	330644	N/A	230744	230744	230744	230744	230744	230744	N/A
**36	Hammer	101038	101273	101273	101273	101273	101273	101273	101273	101273	101273	101273	101273	101038	101273	101273
37	Hammer Screw	301000	301090	301090	301090	301090	301090	301090	301090	301090	301090	301090	301090	301000	301090	301090
38	Hammer Spring (Mainspring)	420294	420294	420294	420294	420294	420294	420294	420294	420294	420294	420294	420294	420294	420294	420294
39	Hammer Spring Adjusting Plate	320175	320175	320175	320175	320175	320175	320175	320175	320175	320175	320175	320175	320175	320175	320175
40	Hammer Spur Complete (Includes parts 41 and 42)	520377	520377	520377	520377	520377	520377	520377	520377	520377	520377	520377	520377	520377	520377	520377
41	Hammer Spur Screw	420193	420193	420193	420193	420193	420193	420193	420193	420193	420193	420193	420193	420193	420193	420193
42	Hammer Spur Wrench	420204	420204	420204	420204	420204	420204	420204	420204	420204	420204	420204	420204	420204	420204	420204
43	Hammer Strut	320174	320174	320174	320174	320174	320174	320174	320174	320174	320174	320174	320174	320174	320174	320174
44	Hammer Strut Pin	401397	401397	401397	401397	401397	401397	401397	401397	401397	401397	401397	401397	401397	401397	401397
45	Loading Spring	101037	101594	101594	101594	101594	101594	101594	101594	101594	101394	101394	101494	101063	101494	101494
46	Loading Spring Screw	301006	301591	301591	301591	301591	301591	301591	301591	301591	301591	301591	301591	301006	301591	301591
*47	Locking Bolt	101081	101081	101081	101081	101081	101081	101081	101081	101081	101081	101081	101081	101081	101081	101081
48	Magazine Tube	201002	201022	201022	201022	201022	201022	201532	214722	201422	201010	201010	201722	201013	201722	101125
49	Magazine Tube Follower	501045	501045	501045	501045	501045	501045	501045	501045	501045	501045	501045	501045	401524	401524	401524
50	Magazine Tube Plug	301004	301225	301225	301225	301225	301225	301225	301425	301425	301015	301015	301325	101069	301325	301325
51	Magazine Tube Plug Screw	301013	301990	301990	301990	301990	301990	301990	301990	301990	301990	301990	301990	101071	301990	301990
52	Magazine Tube Spring	401395	401395	401395	401395	401395	401395	401395	401395	401595	401795	401795	401795	401795	401795	401395
53	Magazine Tube Stud	N/A	N/A	N/A	N/A	N/A	N/A	N/A	201125	201125	201125	201125	201125	101072	201125	201125
***54	Pistol Grip Cap	320808	320808	320808	N/A	N/A	N/A	N/A	N/A	320808	N/A	N/A	N/A	N/A	320808	N/A
55	Pistol Grip Cap Screw	420290	420290	420290	N/A	N/A	N/A	N/A	N/A	420290	N/A	N/A	N/A	N/A	420290	N/A
56	Rear Band	501038	501521	501521	501521	501121	N/A	501521	N/A	N/A	N/A	N/A	N/A	N/A	N/A	N/A
57	Rear Band Screw	301012	301590	301590	301590	301590	N/A	301590	N/A	N/A	N/A	N/A	N/A	N/A	N/A	N/A
58	Rear Sight Assembly	501342	501342	501342	530642	530642	530642	530642	414242	501342	502242	502242	502242	502242	502242	414242
59	Rear Sight Base	520241	520241	520241	N/A	N/A	N/A	N/A	N/A	520241	520241	520241	520241	520241	520241	N/A
60	Rear Sight Elevator	320242	320242	320242	N/A	N/A	N/A	N/A	N/A	320242	320242	320242	320242	320242	320242	N/A
61	Rear Sight Folding Leaf	201342	201342	201342	N/A	N/A	N/A	N/A	N/A	214142	202242	202242	202242	202242	202242	N/A
**62	Receiver	101039	101760	101760	101760	101760	101760	101760	101352	101860	101048	101048	101960	101064	101960	101252
**63	Safety Button Assembly	599380	599383	599383	599383	599383	599383	599383	599383	599383	599383	599383	599383	893830	599383	599383
64	Scope Mount Dummy Screw (4)	320003	320493	320493	320493	320493	320493	320493	320493	320493	320493	320493	320493	320003	320493	320493
*65	Sear	201051	201051	201051	201051	201051	201051	201051	201051	201051	201051	201051	201051	201051	201051	201051
66	Swivel Stud, Rear	305490	420793	420793	420793	407111	420793	420793	N/A	420793	420793	420793	420793	305490	420793	N/A
67	Tang Screw	320002	320391	320391	320391	320391	320391	320391	320391	320391	320391	320391	320391	320002	320391	320391
*6																